

ECR#		REV	DESCR PTIONS	DATE	REV BY	ZONE

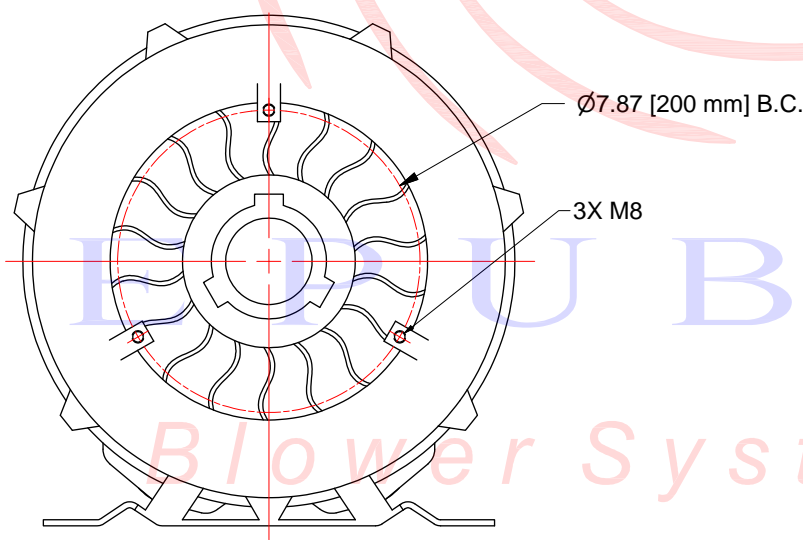
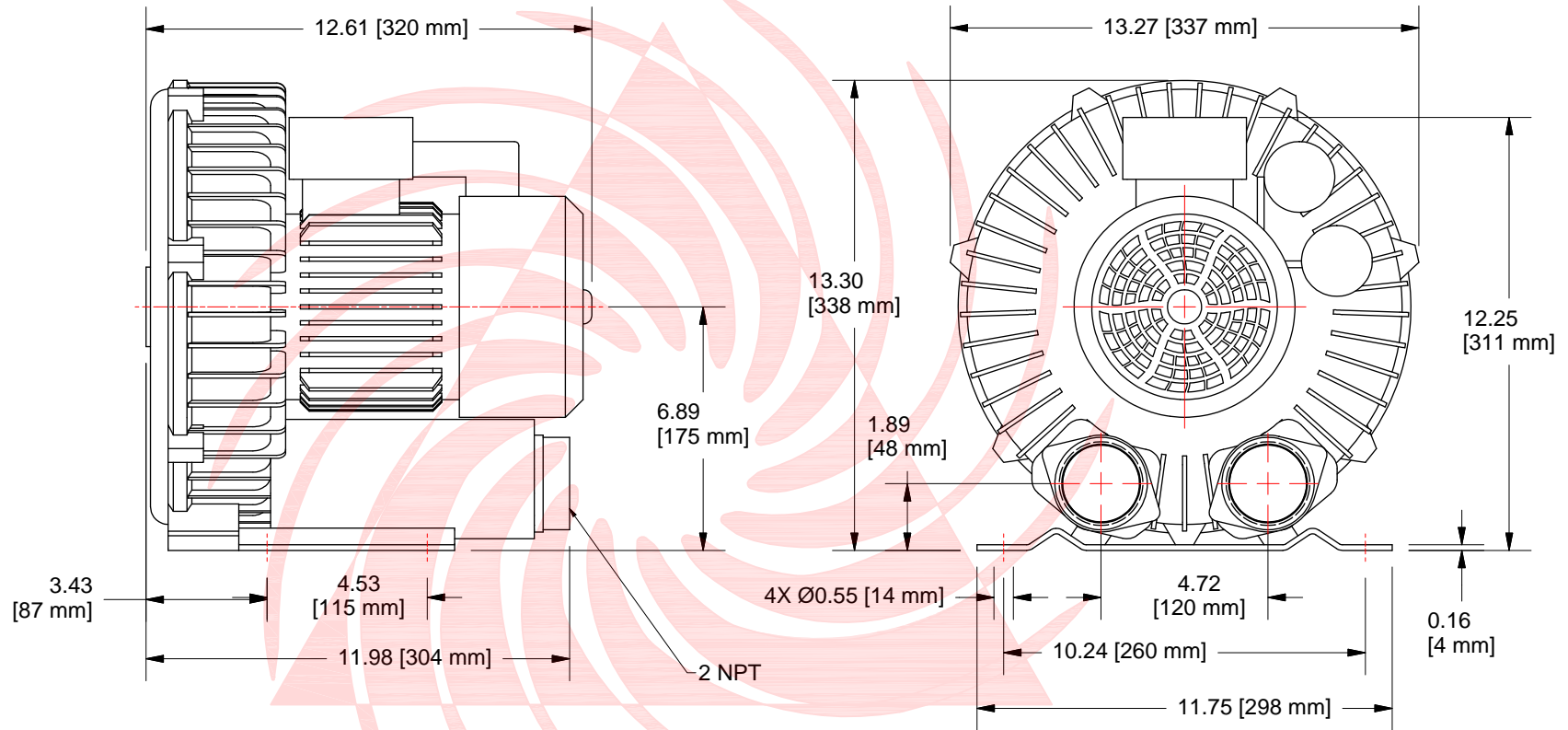

UNLESS OTHERWISE SPECIFIED			DRAWN	DATE	Republic Sales & Mfg.	
ALL DIMENSIONS ARE IN INCHES			R Tandy	1/16/2012	www.republicsales.com	
DECIMALS: .005			ROUTING		TITLE	
FRACT ONS: 1/32			QA		Republic Sales Regen Blower	
ANGLES: 90			MFG		SIZE	DWG NO
BREA K ALL SHARP EDGES			APPROVED		C	HRB401
MACHINE SURFACE FINISH N RMS			MATERIAL		SCALE	REV
NOTICE			FINISH			
PROPR IETY RIGHTS INVOLVED						
THIS DOCUMENT AND ALL ACCOMPANYING INFORMATION AND DATA ARE AND REMAIN THE PROPERTY OF REPUBLIC SALES & MFG. AND ARE NOT TO BE COPIED, REPRODUCED, TRANSMITTED OR DISCLOSED TO OTHERS WITHOUT EXPRESS WRITTEN PERMISSION AND ARE TO BE RETURNED UPON REQUEST. THEREFORE, ALL RIGHTS IN PROPERTY AND NOVEL FEATURES OF THE SUBJECT MATTER ARE EXPRESSLY RESERVED BY REPUBLIC SALES & MFG. RECIP ENTS AGREEMENT TO THE FOREGOING IS INDICATED BY ACCEPTANCE OF THIS DOCUMENT						
					SHEET	1 OF 1