

REVISIONS		DATE	REV BY	ZONE
ECR#	REV	DESCR PTIONS		

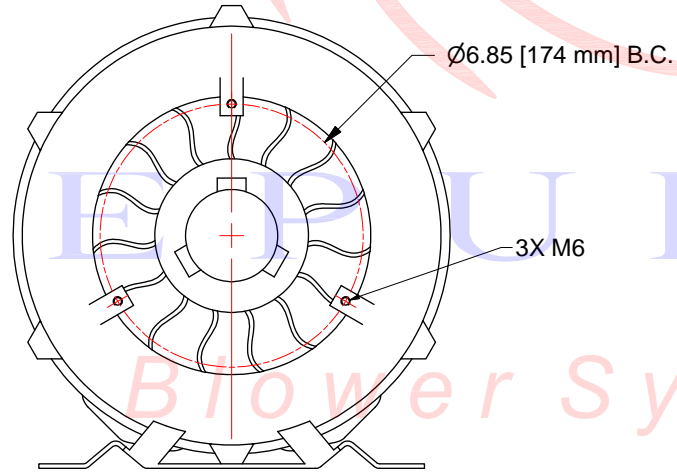
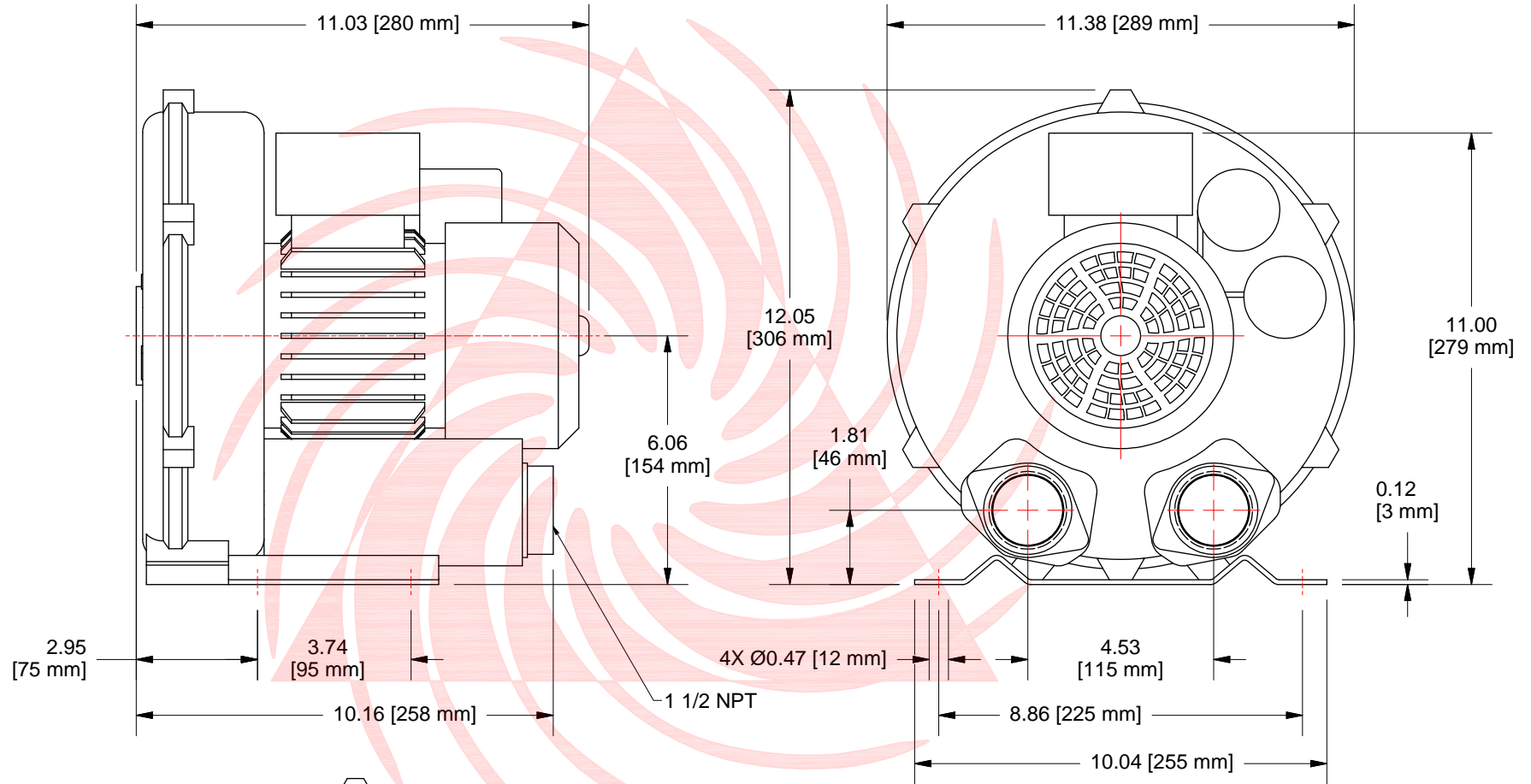

REPUBLIC

Blower Systems

UNLESS OTHERWISE SPECIFIED ALL DIMENSIONS ARE IN INCHES		DRAWN R Tandy	1/16/2012	Republic Sales & Mfg. www.republicsales.com	
DECIMALS: XXX ± .005 XX ± .010	FRACT IONS: ± 1/32	ANGLES: ± 0° 30'	ROUTING	TITLE	
BREAK ALL SHARP EDGES MACHINE SURFACE FINISH IN RMS 12.5			QA	Republic Sales Regen Blower	
NOTICE PROPERTY RIGHTS INVOLVED THIS DOCUMENT AND ALL ACCOMPANYING INFORMATION AND DATA ARE AND REMAIN THE PROPERTY OF REPUBLIC SALES & MFG. AND ARE NOT TO BE COPIED, REPRODUCED, REPRODUCED, NOR TRANSMITTED OR DISCLOSED TO OTHERS WITHOUT EXPRESS WRITTEN PERMISSION AND ARE TO BE RETURNED UPON REQUEST. THEREFORE, ALL RIGHTS IN PROPERTY AND NOVEL FEATURES OF THE SUBJECT MATTER ARE EXPRESSLY RESERVED BY REPUBLIC SALES & MFG. RECIPIENTS AGREEMENT TO THE FOREGOING IS INDICATED BY ACCEPTANCE OF THIS DOCUMENT.			MFG	SIZE DWG NO C HRB201	
			APPROVED	REV	
			MATERIAL	SCALE	
			FINISH	SHEET 1 OF 1	