

REVISIONS		DATE	REV BY	ZONE
ECR#	REV	DESCR PTIONS		

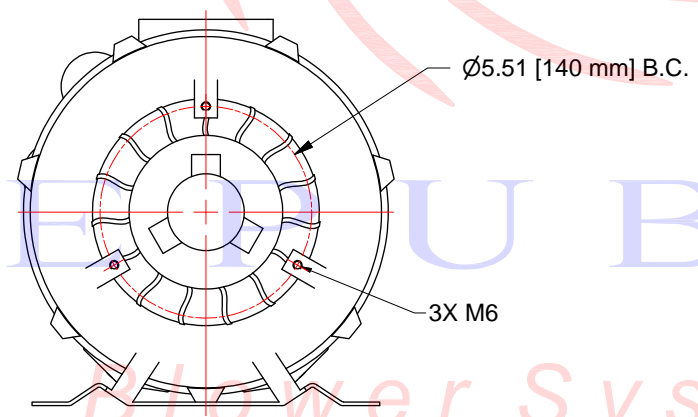
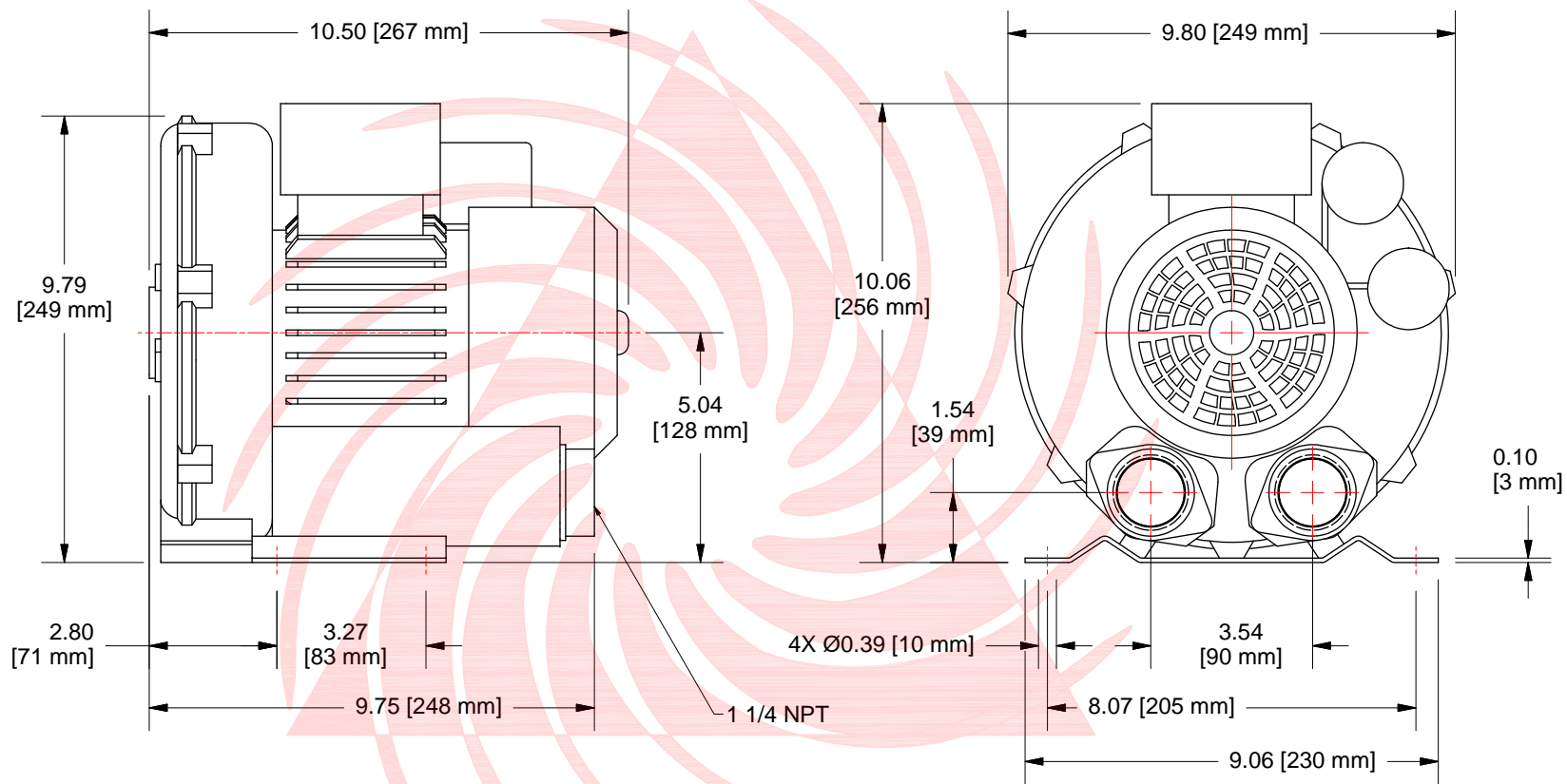

REPUBLIC

Blower Systems®

UNLESS OTHERWISE SPECIFIED ALL DIMENSIONS ARE IN INCHES		DRAWN R Tandy	1/16/2012	Republic Sales & Mfg. www.republicsales.com	
TOLERANCES**		ROUTING		TITLE	
DECIMALS: XXX ± .005 XX ± .010	FRACT ONS: ± 1/32	QA		Republic Sales Regen Blower	
ANGLES: ± 0° 30'		MFG		SIZE	DWG NO
BREAK ALL SHARP EDGES MACHINE SURFACE FINISH IN RMS 12.5		APPROVED		C	HRB101
NOTICE PROPRIETY RIGHTS INVOLVED THIS DOCUMENT AND ALL ACCOMPANYING INFORMATION AND DATA ARE AND REMAIN THE PROPERTY OF REPUBLIC SALES & MFG. AND ARE NOT TO BE COPIED, REPRODUCED, REPRODUCED, TRANSMITTED OR DISCLOSED TO OTHERS WITHOUT EXPRESS WRITTEN PERMISSION AND ARE TO BE RETURNED UPON REQUEST. THEREFORE, ALL RIGHTS IN PROPERTY AND NOVEL FEATURES OF THE SUBJECT MATTER ARE EXPRESSLY RESERVED BY REPUBLIC SALES & MFG. RECIP ENTS AGREEMENT TO THE FOREGOING IS INDICATED BY ACCEPTANCE OF THIS DOCUMENT		MATERIAL		SCALE	SHEET 1 OF 1
		FINISH			REV