

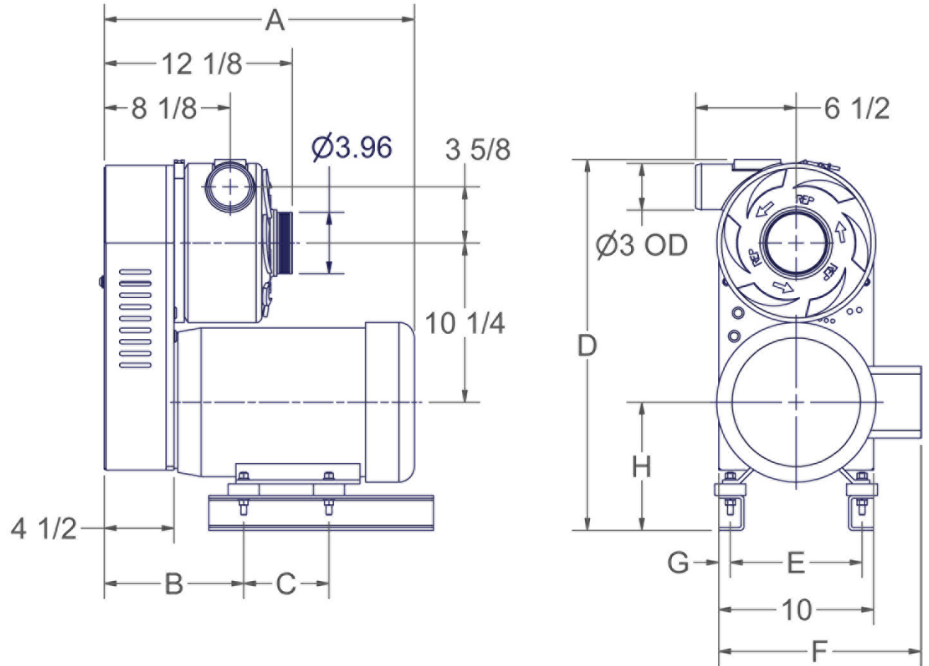

**REPUBLIC**  
Blower Systems®



# Republic Centrifugal Blower RB 800



## RB 800 Specifications

- ▲ 3-15 Horsepower – Up to 20,000 RPM
- ▲ Smallest Footprint – Ideal Inside Machine Cabinets
- ▲ Ceramic Hybrid Bearings
- ▲ Multi-lip Seals on Both Ends of the Shaft
- ▲ Easy to Remove Bearing/Impeller Housing for Quick Repair
- ▲ Lightweight, small envelope design
- ▲ Automatic self-adjusting belt tensioner
- ▲ Hard Anodized (Optional)
- ▲ Blower Outlet Discharge is Rotatable 360°
- ▲ Precision Balanced Shaft/Impeller Assemblies
- ▲ Nickel Plated Steel Motor Pulley
- ▲ Stainless Steel Blower Pulley
- ▲ Alluminum Blower Housing
- ▲ 6061 T6 Aluminum Impeller
- ▲ Bearing Housing is Steel Construction for Extra Rigidity
- ▲ 16 Groove Belt for Long Life
- ▲ Inlet and Outlet Flanges Available
- ▲ Enclosures for Noise Control
- ▲ Protection Against Contaminants
- ▲ Operational with all Types of Blowers – Washdown, Explosion Proof, High Efficiency and Hydraulic
- ▲ 100% Operational Performance and Vibration Tested
- ▲ One Year Warranty
- ▲ Water-cooled Blower Available
- ▲ 3" Standard Discharge, 4" Discharge Optional

HP	A	B	C	D	E	F	G	H
3 (182T)	17 1/16	8 1/8	4 1/2	23 1/8	7 1/2	11 7/8	1 1/4	7 1/2
5 (184T)	17 1/16	8 1/8	5 1/2	23 1/8	7 1/2	11 7/8	1 1/4	7 1/2
7 1/2 (213T)	20	9	5 1/2	23 7/8	8 1/2	13 1/16	3/4	8 1/4
10 (215T)	20 3/8	9	7	23 7/8	8 1/2	13 1/16	3/4	8 1/4
15 (254T)	22 5/8	9	7	23 7/8	8 1/2	13 1/16	3/4	8 1/4

HP	Est. WGT. (lbs)
3 (182T)	138
5 (184T)	149
7 1/2 (213T)	198
10 (215T)	226
15 (254T)	243

Retro Kit Est. WGT. (lbs)	68
---------------------------	----

Noise Control	With Enclosure	No Enclosure
With Silencer	74-78 dB	88-90 dB
No Silencer	80-82 dB	92-96 dB

5131 Cash Road ▲ Dallas, TX 75247 ▲ P 214.631.8070 ▲ F 214.631.3673 ▲ 800.847.0380

[www.republicsales.com](http://www.republicsales.com)



# Republic Centrifugal Blower Performance Curves

**REPUBLIC**  
Blower Systems®

## Pressure vs. CFM

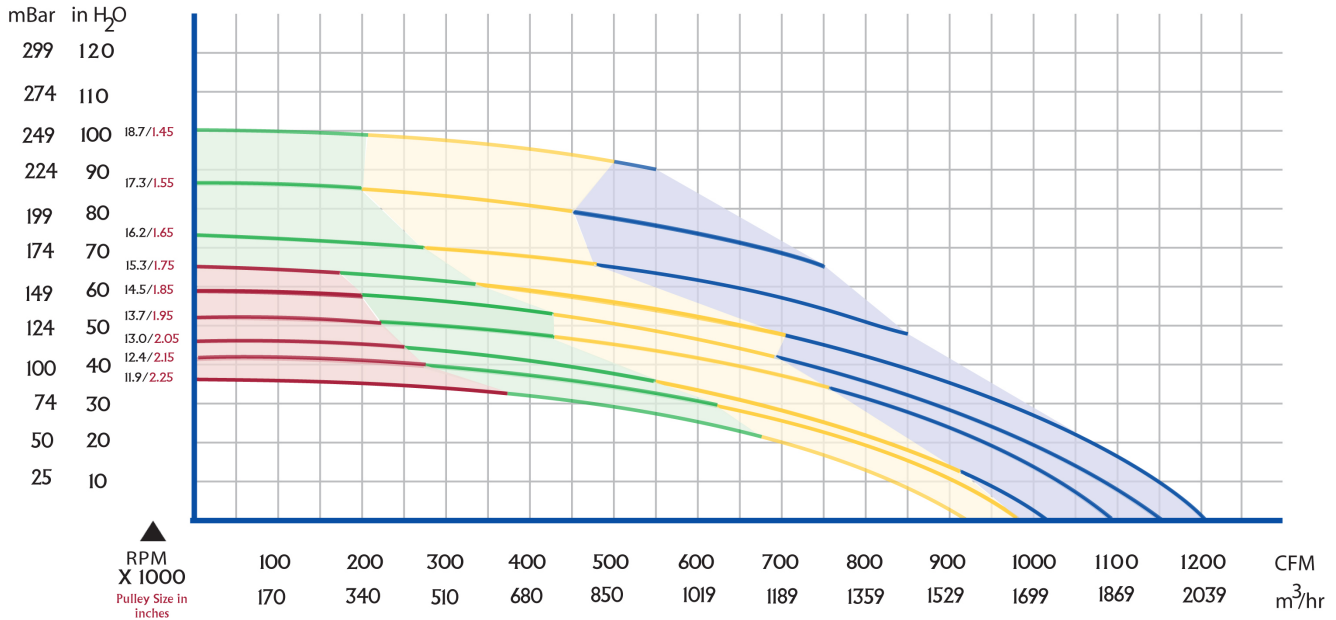

## Vacuum vs. CFM

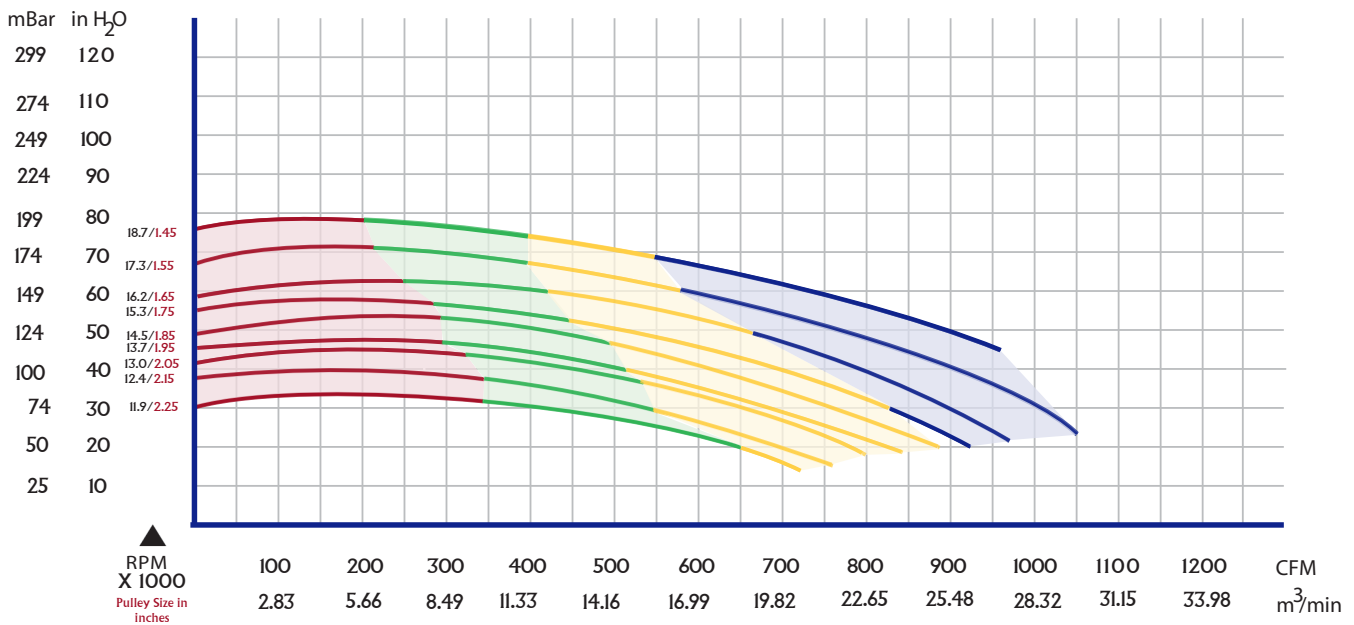

Standard cubic feet per minute, air at 14.7 psia, 68°F, 36% R.H.  
1" H<sub>2</sub>O = .074" Hg = .036 PSIG = .57 oz = 25.4 mm H<sub>2</sub>O

■ RB 800-5 HP    
 ■ RB 800-7.5 HP    
 ■ RB 800-10 HP    
 ■ RB 800-15 HP

5131 Cash Road ▲ Dallas, TX 75247 ▲ P 214.631.8070 ▲ F 214.631.3673 ▲ 800.847.0380

[www.republicsales.com](http://www.republicsales.com)

©2011 Republic Sales & Manufacturing  
Modified 09/11  
280-0079